

## ECV200 CONTROL BOX

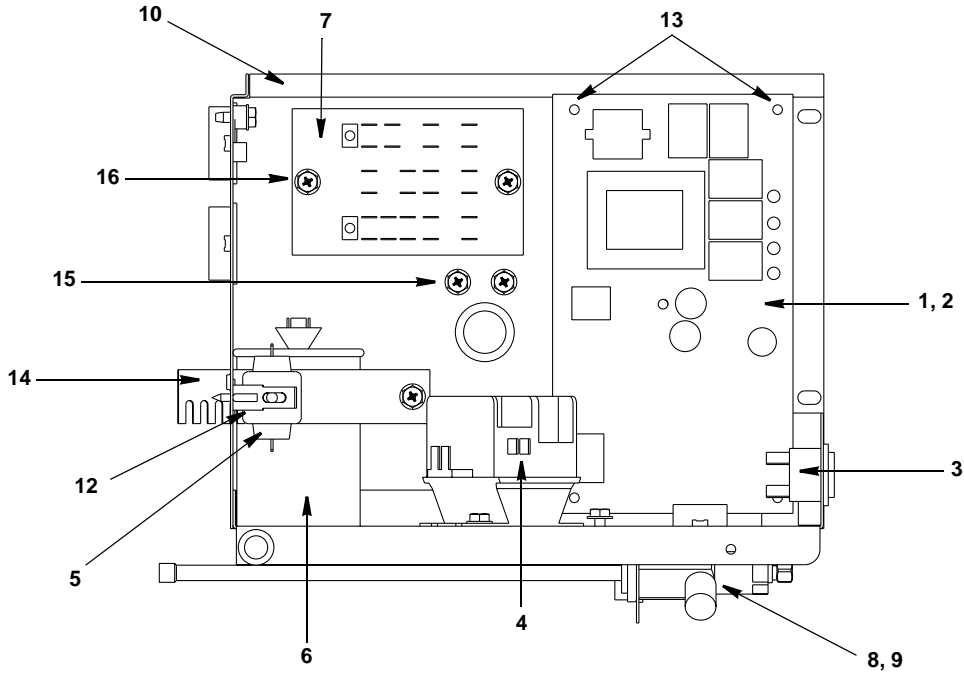

pt1176

### DESCRIPTION

	<b>PART NO.</b>
1 Control Board (for use with all voltages) . . . . .	† 76-2782-3
2 7 Amp Fuse – Mounted on Control Board . . . . .	25-1100-3
3 <b>Toggle Switch</b> Only . . . . .	23-0134-3
a. Toggle Switch with Wiring Harness Attached . . . . .	20-3217-3
4 <b>Contactor</b> . . . . .	† 20-0154-3
5 P.T.C.R. Compressor Starter . . . . .	85-0500-3
6 <b>Compressor Run Capacitor</b> . . . . .	85-0400-3
7 <b>Terminal Board with Wire Harness Attached</b> - 230V/60 Hz/1 Ph. . . . .	20-3229-3
8 Refrigeration Service Valve Assembly . . . . .	83-7326-3

### Miscellaneous – Brackets, Screws, etc.

9 Locknut Used to Mount Refrigeration Service Valves. . . . .	† 54-7503-9
10 Control Box . . . . .	602559-3
11 Control Box Cover (Not shown) . . . . .	† 76-2852-3
12 P.T.C.R. Compressor Starter Mounting Bracket . . . . .	85-0502-3
13 Control Board Mounting Supports . . . . .	43-0225-3
14 Capacitor Mounting Strap . . . . .	602495-1
15 Screw, #10-24 x .50 Ground . . . . .	† 52-0216-9
16 Screw, #10-24 x .50 . . . . .	† 52-0206-9

## ECV200 EVAPORATOR COMPARTMENT

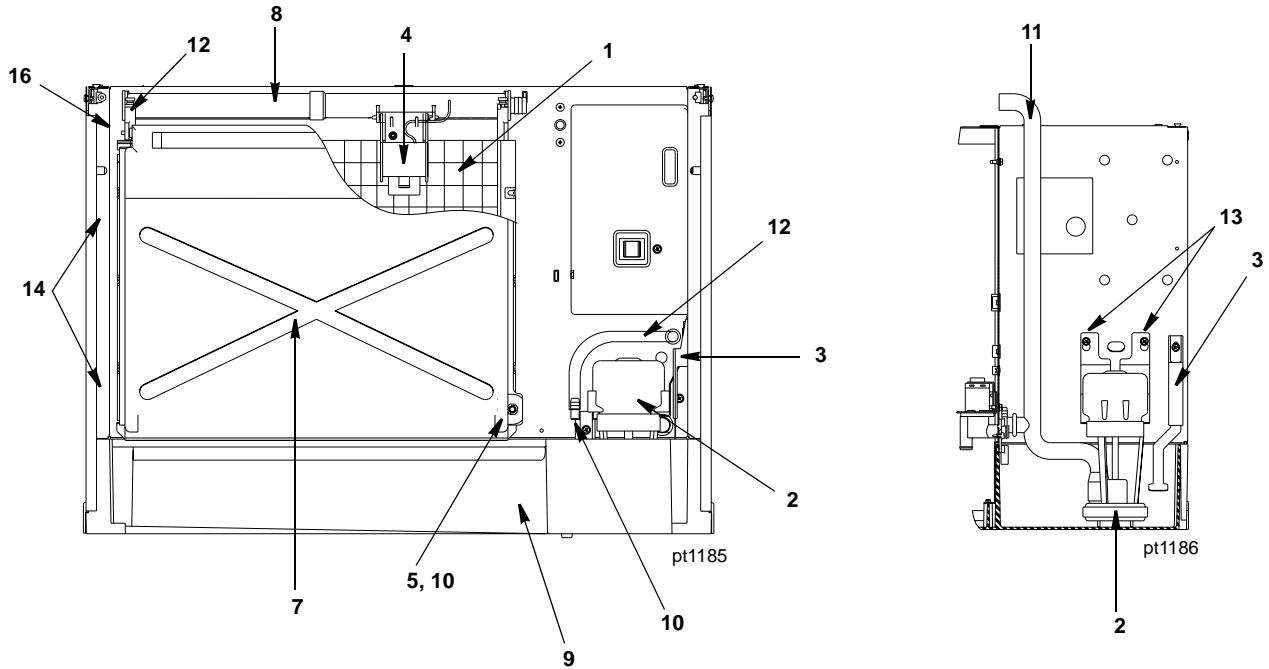

### DESCRIPTION

	DESCRIPTION	PART NO.
1	<b>Evaporator Assembly</b>	
	a. Regular Cube . . . . .	† 76-2512-9
	b. Dice Cube . . . . .	† 76-2511-9
	c. Half Dice Cube . . . . .	† 76-2510-9
2	<b>Water Pump</b> . . . . .	† 76-2601-3
3	<b>Float Valve</b> . . . . .	83-6904-9
	a. Strainer . . . . .	83-6906-9
	b. Cap . . . . .	83-6914-9
	c. Nut . . . . .	56-5072-9
	d. Plunger . . . . .	83-6908-9
4	Ice Thickness Control Probe . . . . .	† 76-2781-3
5	Magnetic Bin Switch (Mounted to Evaporator). . . . .	† 23-0148-3
6	Water Flow Clamp – Use on Regular Cube Evap. Only (Not shown) . . . . .	76-2054-3
7	Water Curtain . . . . .	† 43-0464-3
8	Water Distribution Tube . . . . .	† 76-2498-3
9	Water Trough . . . . .	40-0020-3

### Miscellaneous – Brackets, Screws, etc.

10	Water Curtain Magnet with Attachment Clip . . . . .	† 76-2802-3
11	Tubing (Water Pump Out) . . . . .	44-2109-3
12	Screw, #8-32 x .63 Nylon Water Distribution Tube Mounting. . . . .	† 50-0001-3
13	Screw, #10-24 x .50 . . . . .	† 52-0206-9
14	Screw, #10-24 x .750 Used to Mount Evaporator . . . . .	† 52-0218-9
15	Evaporator Top Molding and Gasket Assembly . . . . .	76-2621-3
16	Water Curtain Pin Assembly . . . . .	76-2776-3
17	Float Valve Bracket . . . . .	620682-4

## ECV200 REFRIGERATION COMPARTMENT – COMMON PARTS

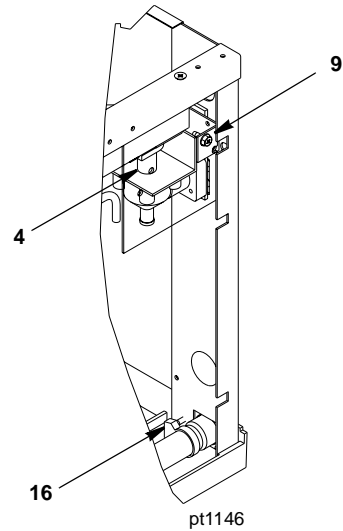
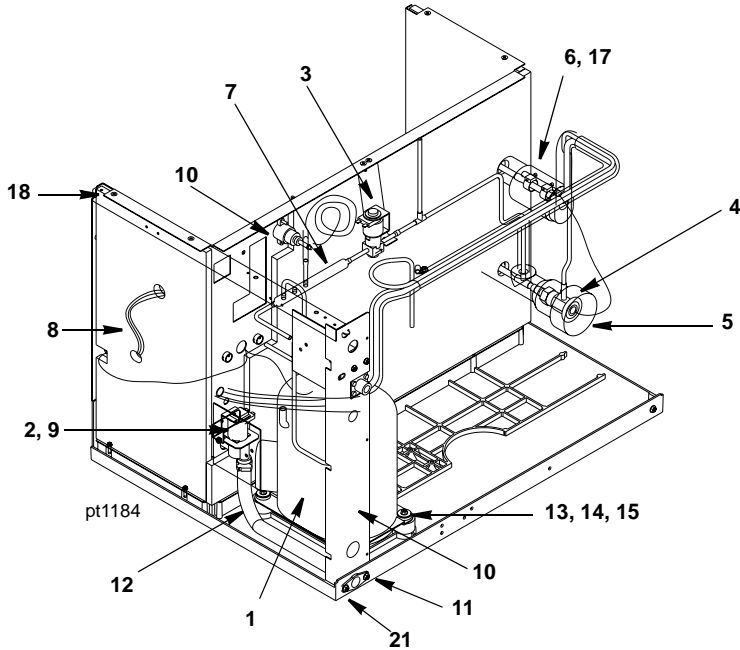

### DESCRIPTION

	DESCRIPTION	PART NO.
1	<b>Compressor</b> .....	† 76-2811-3
2	<b>Water Dump Valve</b>	
	a. Dump Valve Assembly without Electrical Coil. ....	† 24-0520-3
	b. Dump Valve Coil Only .....	24-0522-3
	c. Dump Valve Rebuild Kit .....	24-0501-3
3	<b>Hot Gas Valve</b>	
	a. Hot Gas Valve Including Electrical Coil (Danfoss) .....	† 76-3007-1
	b. Hot Gas Valve Coil Only Danfoss .....	20-0177-3
	c. Hot Gas Valve Coil Only Alco .....	† 24-0448-3
4	<b>Expansion Valve</b> .....	† 76-0019-3
5	Expansion Valve Body Insulation Boot	
	a. Alco .....	40-0721-3
	b. Danfoss .....	40-0036-3
6	Expansion Valve Bulb Insulation Boot .....	40-0720-3
7	Manifold Strainer (in front of hot gas valve) .....	83-1023-3
8	Water Pump Electrical Wire Lead .....	† 20-7810-3
8	High Pressure Cut-out (Auto Reset) .....	23-5543-3
	<b>Miscellaneous – Brackets, Screws, etc.</b>	
9	Dump Valve Mounting Bracket .....	602354-1
10	Right Corner Post Weldment .....	603999-1
11	Water Drain Female Wing Adapter .....	87-0608-3
12	Water Drain Vinyl Tubing, .625 ID .....	† 44-2038-3
13	Compressor Mounting Rubber Grommet .....	† 85-0306-9
14	Compressor Mounting Washer .....	† 55-7341-9
15	Compressor Mounting Screw .....	† 50-1230-9
16	Clamp, Water Drain .....	† 56-5070-9
17	Clamp, Expansion Valve Bulb .....	† 56-5052-9
18	Screw, #10-24 x .50 .....	† 52-0209-9
19	Terminal Block (50 Hz Only) .....	20-0614-3

## EVC200 REFRIGERATION COMPARTMENT – AIR-COOLED

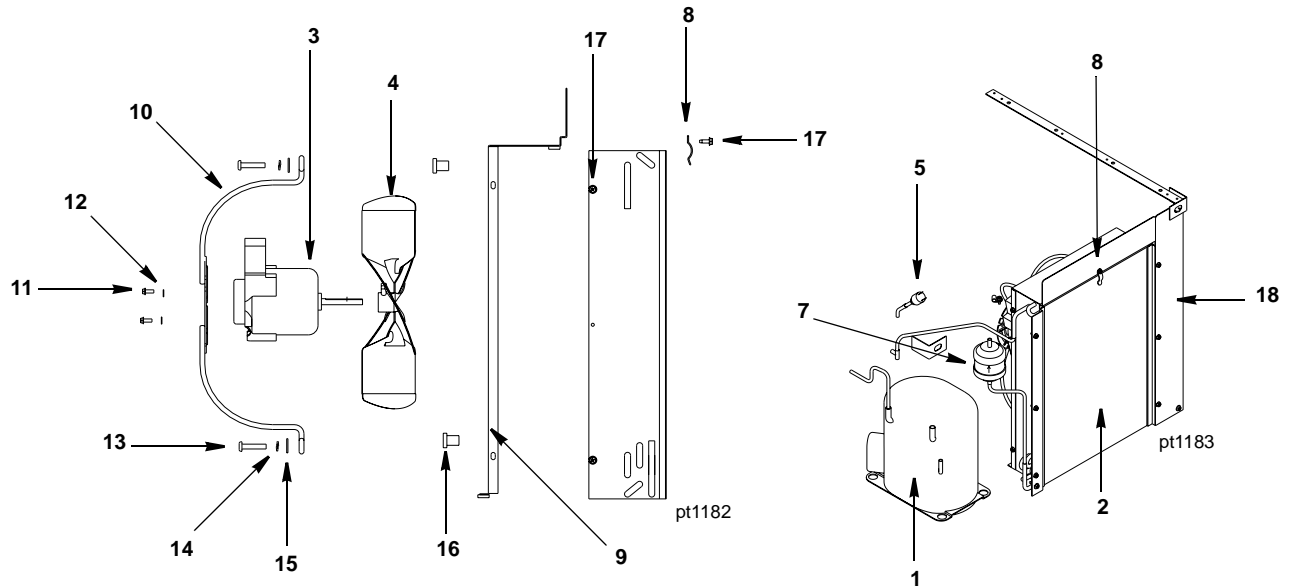

### DESCRIPTION

		<b>PART NO.</b>
1	Compressor (Refer to COMMON PARTS Page) . . . . .	Page 4
2	Air Condenser . . . . .	88-5124-3
3	Fan Motor . . . . .	† 24-1293-9
4	Fan Blade . . . . .	24-1620-3
5	Fan Cycling Control . . . . .	† 20-0126-3
6	Air Filter (Not shown) . . . . .	30-0054-3
7	Drier . . . . .	† 89-3025-3

### Miscellaneous – Brackets, Screws, etc.

8	Air Filter Clip . . . . .	† 56-5069-9
9	Fan Shroud . . . . .	604086-1
10	Fan Motor Mounting Bracket . . . . .	34-0662-3
11	Fan Motor Mounting Screw . . . . .	† 50-2559-9
12	Fan Motor Mounting Flatwasher . . . . .	† 55-0426-9
13	Fan Bracket Mounting Screw . . . . .	† 50-3358-9
14	Fan Bracket Mounting Lockwasher . . . . .	† 55-4510-9
15	Fan Bracket Mounting Flatwasher . . . . .	† 55-7305-9
16	Fan Bracket Mounting Rubber Wellnut . . . . .	† 54-2955-9
17	Screw, #10-24 x .50 . . . . .	† 52-0206-9
18	Left Corner Post Weldment . . . . .	604001-1

## ECV200 PANELS

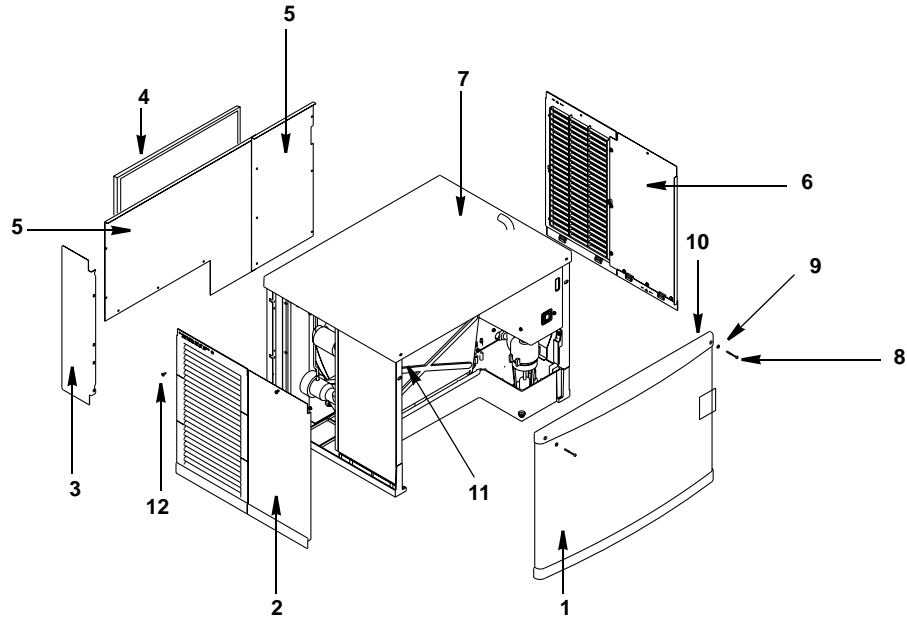

pt1177

### DESCRIPTION

DESCRIPTION	PART NO.
1 Front Panel Assembly . . . . .	76-0065-3
2 Left Side Panel . . . . .	76-0066-3
3 Air Baffle . . . . .	602363-1
4 Air Filter . . . . .	40-4018-3
5 Back Panel . . . . .	604136-1
6 Right Side Panel . . . . .	76-0067-3
7 Top Cover . . . . .	43-0015-3

### Miscellaneous – Brackets, Screws, etc.

8 Front Cover Screw . . . . .	† 51-1901-9
9 Front Cover Washer . . . . .	† 55-7338-9
10 Front Cover Screw Retainer . . . . .	† 56-4827-9
11 Speed Nut Assembly to Mount Front Cover . . . . .	† 54-7303-9
12 Screw, #10-24 x .50 Flat . . . . .	† 52-0209-9
13 Extruded Tape (Not shown) . . . . .	† 92-0250-9
14 Front Top Support (Not shown) . . . . .	† 658041-9